

Sample Site Plan

All applications must include a site plan. The site plan shows the preferred location of the house, driveway, and any other proposed structures. The proposed location of the septic system and well may also be shown. The site plan should be provided on either a survey plat or GIS aerial photo of the property. This is for sample only not to be used as your site plan.

ROAD NAME

The sample site plan must include the following information as shown in diagram:

- Dimensions of the property (Existing or proposed)
- Proposed size and location of the house (exact footprint is not required) Must show measurements from at least 2 property lines
- Proposed driveway
- Proposed location of septic system and well (optional)
- Location and size of additional structures (proposed or future additions) i.e. sheds, garage, workshop, pool etc.
- Location of wells or septic systems on adjacent properties (if known)
- Location of any easements (access, power lines or others) on the property (if known)

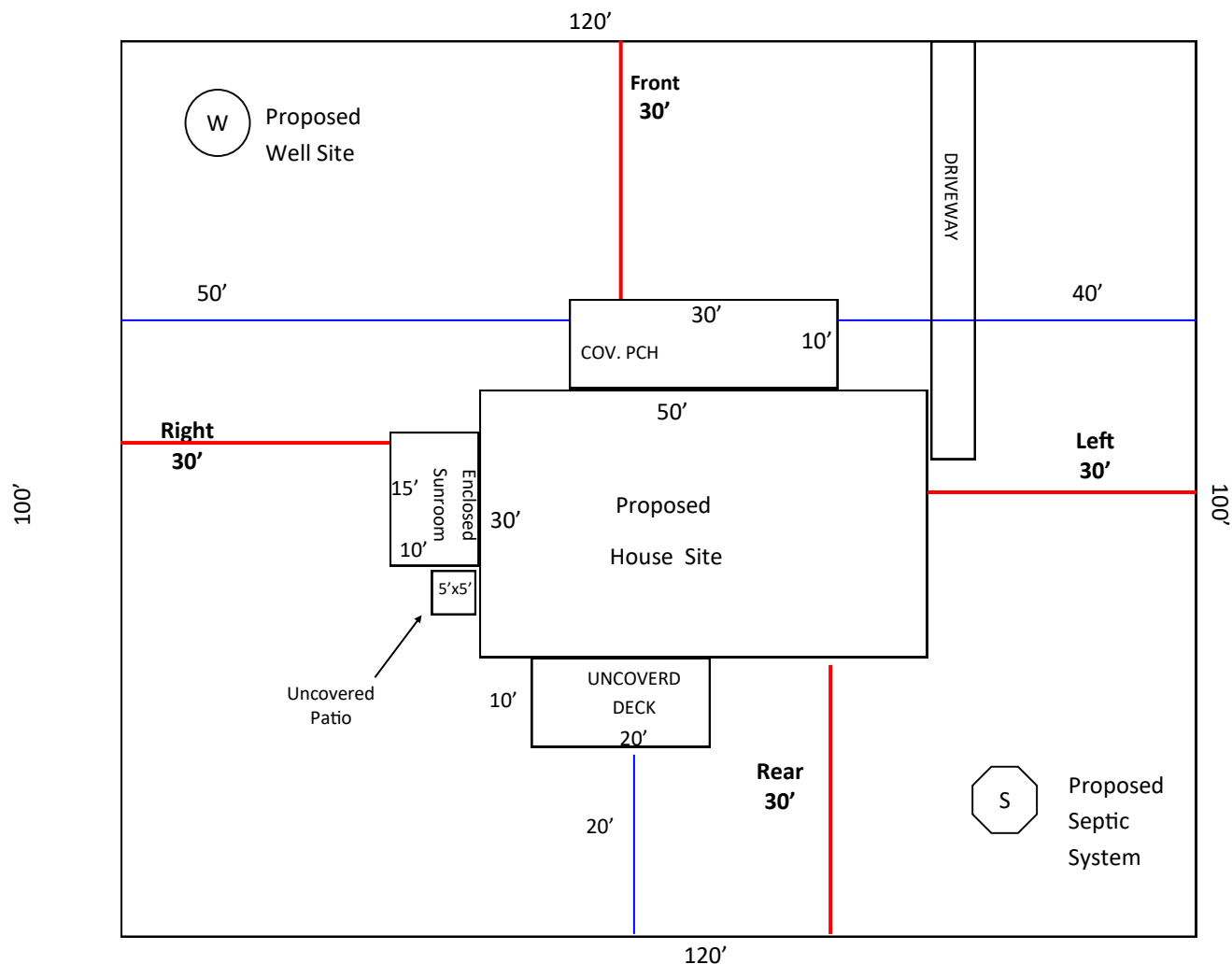

**** Note:** The site plan does not have to be to scale and can be hand drawn, but must show the configuration of the proposed lot.